

REV B
SHEET 1
DWG NO. 50-T-MT

SPECIFICATIONS:

POWER RATING: 50 W MAX. @ 40°C.

60 W MAX. @ 25°.

FREQUENCY RANGE & VSWR:

DC TO 1GHz AT 1.10:1 MAX.

1GHz TO 4GHz AT 1.25:1 MAX.

IMPEDANCE: 50 OHMS, NOMINAL

AMBIENT TEMPERATURE RANGE: -40°C TO +40°C

CONNECTOR: TNC MALE (TRI-ALLOY PLATED)

OPERATING POSITION: ANY (CONVECTION COOLED)

FINISH: BLACK ANODIZED

NOMINAL SIZE: APPROX. 4.85" X 2.30"

WEIGHT: APPROX. 1.1 LBS

| REVISIONS | | | | |
|-----------|-----|-------------|----------|----------|
| ZONE | REV | DESCRIPTION | DATE | APPROVED |
| | A | ECN #0012 | 11-20-95 | MEV |
| | B | ECN #0201 | 9-2-98 | MEV |

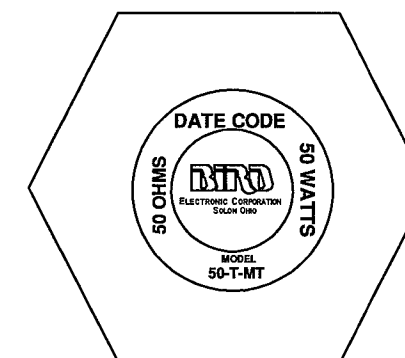
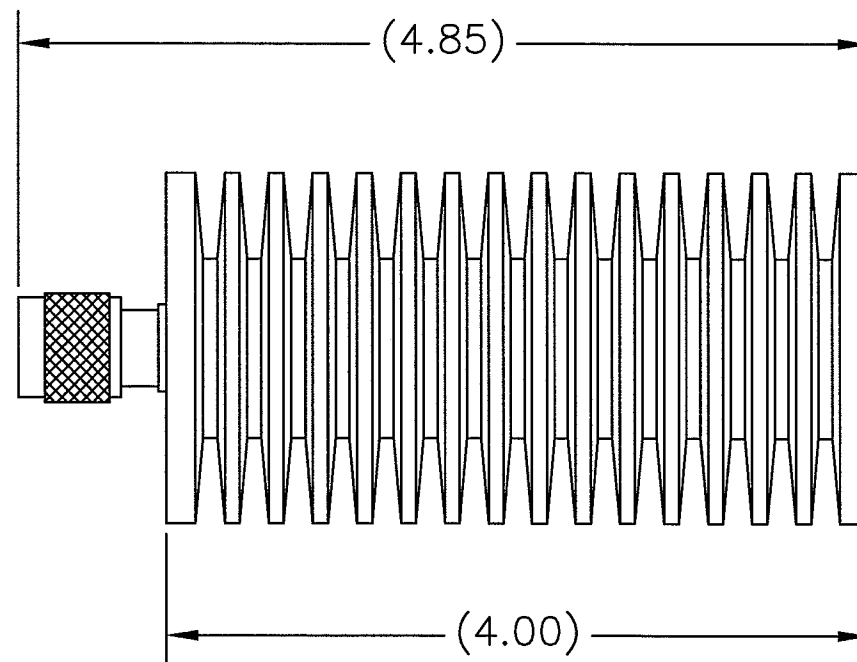
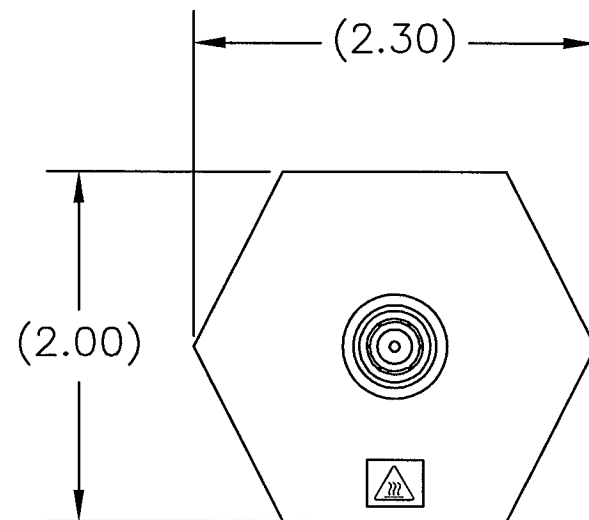

DIMENSIONS HEREON ARE FOR CUSTOMER CONVENIENCE AND REFERENCE ONLY. TOLERANCE TO BE APPLIED ONLY WHERE INDIVIDUALLY STATED ON THE RESPECTIVE DIMENSION. -DO NOT SCALE DRAWING-

UNLESS OTHERWISE SPECIFIED DIMENSIONS ARE IN INCHES TOLERANCES ARE:
 FRACTIONS DECIMALS ANGLES
 ± 1/64 .XX = ±.010 ± 30'
 .XXX = ±.005
 MILLIMETERS
 .X = ±.4
 .XX = ±.12
 DO NOT SCALE DRAWING

THIS DRAWING IS THE PROPERTY OF THE BIRD ELECTRONIC CORPORATION. THE DESIGNS AND SPECIFICATIONS DISCLOSED HEREON ARE PROPRIETARY AND SHALL NOT BE REPRODUCED, NOR COPIED, NOR USED AS THE BASIS FOR THE MANUFACTURE OR SALE OF APPARATUS OR DEVICES WITHOUT THEIR EXPRESS WRITTEN CONSENT.



| | | | | | |
|----------|-----------|---------|------------------------------|-----------|----------|
| MATERIAL | APPROVALS | DATE | TITLE | | |
| | D.M.RINK | 6-16-03 | TERMINATION TNC MALE, 50W | | |
| FINISH | CHECKED | | SIZE | FSCM NO. | DWG. NO. |
| | APPROVED | MEV | B | 70998 | 50-T-MT |
| | | 6-23-03 | SCALE | COMM CODE | SHEET |
| | | AUTOCAD | 1:1 | LD1 | 1 OF 1 |